



### ● Model BB-SC

Axle: Cr-Mo Steel.  
Cup & Nut: Duralumin, Anodized, Steel, Chrome Plating (C.P.) Sealed Bearing type.

Thread: 1.37" x 24T (R.L.)  
Available for 68mm, 70mm in B.B. Widths.  
Weight: Duralumin Cup & Nut + Axle 250g 8.82 oz  
Steel Cup & Nut + Axle 300g 10.6 oz

Suitable for Crank Models  
(MS) SAMC, MCVS, MCS.  
(MW) DAMC, MCVD, MCCD, MCD, MTD.  
(SB) DAT, DAAS, ASD, DGS, DGT, DRT, DBT.  
(RB) TAT, TPX, TGT, TRT, TBT.  
(RRB) MTB use.

### ● Model CV-SC

Axle: Cr-Mo Steel, Black finish  
Cup: Sealed Bearing type Light alloy, Anodized.

Cup Force-fitting dia: 51.5mm  
Weight: 480g 16.9 oz  
Suitable for Crank Models  
(MC) DAMC, MCVD, MCCD, MCD, MTD.  
(M) DAT, DAAS, ASD, DGS, DGT, DRT, DBT.  
(H) CT-BMX, AT-BMX, GT-BMX, MAXY-CROSS  
(FT) FT-BMX

### ● Model OPC-SC

Cup is Duralumin, Anodized.  
Sealed Bearing type.  
Cup Force-fitting dia: 51.5mm  
Weight: 195g 6.87 oz  
Suitable for U.S.A. type one-piece crank

### BB-SC

MODEL	D	C	A	R'
MS	114.5	18	16	65
MW	118.5	21.5	16	69
SB	124.5	26	16	74
RB	129	30.5	16	78.5
RRB	136	31	24	78.5

### CV-SC

MODEL	D	C	R'
MC	122	22.5	69.5
M	128	27	74
H	131	30	77
FT	132	31	78.2

### AXLE SPECIFICATION

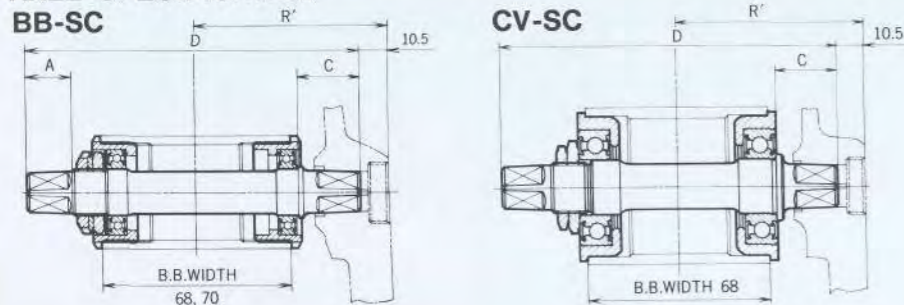

Crank is gravity-Cast light alloy, Cotterless Type. Crank and arm are Cast in one piece.



### SUGINO RT

#### ● Model DRT

Crank Length: 165, 170, 175mm  
Chainring: 1/2" x 3/32"  
Outer: 50, 52T  
Inner: 34, 36, 39, 40, 42, 44, 45T  
Weight: 660g 23.28 oz (52 x 40 x 170 Right and Left Crank)  
B.B. Axle: Maxy type Axle

#### ● Model TRT

Crank Length: 165, 170, 175mm  
Chainring: 1/2" x 3/32"  
Outer: 50, 52T  
Center: 42, 44, 45, 46T  
Inner: 24, 26, 28, 30, 34, 36, 39, 40T  
Weight: 750g 26.45 oz (52 x 40 x 28 x 170 Right and Left Crank)  
B.B. Axle: Maxy type Axle

### SUGINO BT

#### ● Model DBT

Crank Length: 165, 170, 175mm  
Chainring: 1/2" x 3/32"  
Outer: 46, 48, 50, 51, 52, 53T  
Inner: 34, 36, 39, 40, 42, 44, 45T  
Weight: 690g 24.34 oz (52 x 40 x 170 Right and Left Crank)  
Chainguard: Model G5DP, G5D  
B.B. Axle: Maxy type Axle

#### ● Model TBT

Crank Length: 165, 170, 175mm  
Chainring: 1/2" x 3/32"  
Outer: 46, 48, 50, 51, 52, 53T  
Center: 42, 44, 45, 46T  
Inner: 24, 26, 28, 30, 34, 36, 39, 40T  
Weight: 780g 27.51 oz (52 x 40 x 28 x 170 Right and Left Crank)  
B.B. Axle: Maxy type Axle